

UE-PH30H-40



1. Preface

This specification is suitable for the performance of the **UE-PH30H-40** Ni-MH button rechargeable battery.

2. Model

UE-PH30H-40

3. Appearance

There shall be no such defects as discoloration, electrolyte leakage or no voltage.

4. Nominal specification

Description		Specification	
Model		UE-PH30H-40	
Size		PH30K	
Dimensions	Diameter (mm)	11.8max	
	Height (mm)	5.4±0.4	
	Weight(g)	Approx 2.5g	
Nominal Voltage(V)		1.2 V	
Nominal capacity (mAh)		40	
Internal Impedance(mΩ)		≤ 1500	
Discharge Cut-off Voltage		1.0V	
Ambient temperature	Charge	standard	0°C to 40°C
		quick	10°C to 40°C
	Discharge		-10°C to 50°C
	Storage	<1 year	-10°C to 30°C
<3 months		-10°C to 40°C	

5. Characteristics

Unless otherwise specified, the standard range of atmospheric conditions as follows:

- Ambient Temperature 20±5°C

· Relative Humidity $65 \pm 20\%$

· Atmospheric Pressure $960 \pm 100\text{mbar}$

· Voltmeters and ammeters to be used in test shall be of grade 0.5 over

Test Item		Condition	Specification
1. Charge	Standard	Charge at $0.1C_5$ for 16 hours	
	Quick	Charge at $0.2C_5$ for 7 hours	
2. Standard Discharge		Discharge At $0.2C_5$ to 3.0V	
3. Discharge Cut-off Voltage			1.0V
4. Capacity	Nominal	Standard Charge/Discharge	40mAh
	Typical	Standard Charge/Discharge	45mAh
5. Internal resistance		After charge at $0.2C_5$ to for 2.5 hours, rest 5 hours, measured at 1000Hz	$\leq 1500\text{m}\Omega$
6. Cycle life		Standard by IEC	Capacity Retention $\geq 65\%$ After 500 cycles
7. Self-Discharge		The charged battery is stored for 28 days at $20^\circ\text{C} \pm 5^\circ\text{C}$. And the discharge time is measured at standard discharge	≥ 180 minutes
8. High Temperature Test		Store at 50°C for 2 hours then at $0.2C$ Discharge, first, charge at $0.1C$ for 16h at $20^\circ\text{C} \pm 5^\circ\text{C}$.	≥ 270 minutes
9. Low Temperature Test		Store at 0°C for 2 hours then at $0.2C$ Discharge, charge at $0.1C$ 16h at $20^\circ\text{C} \pm 5^\circ\text{C}$ first.	No leakage
10. Short Circuit Test		Short circuit after fully charge	No explode
11. Drop Test		Free fall on the concrete from 1 meter using to 3 axis after fully charged	No leakage No short-circuit No Creak of sleeve

6. Physical

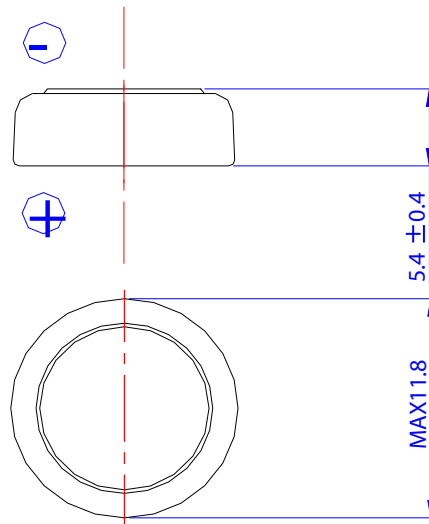

7. Charge / discharge curve (charge at 0.1C, discharge at 0.2C)

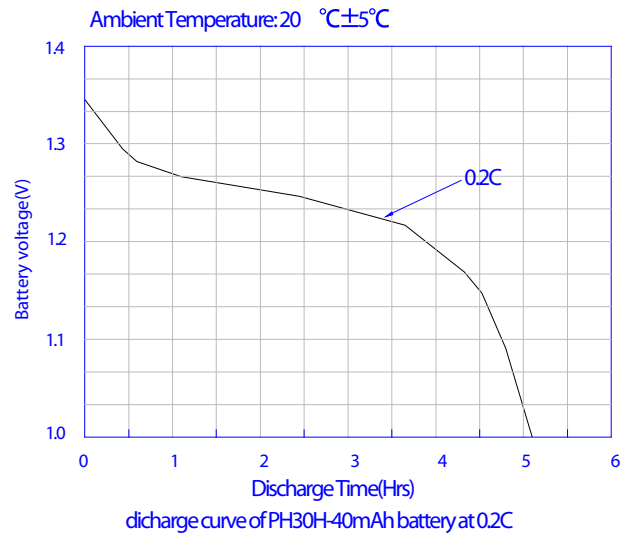
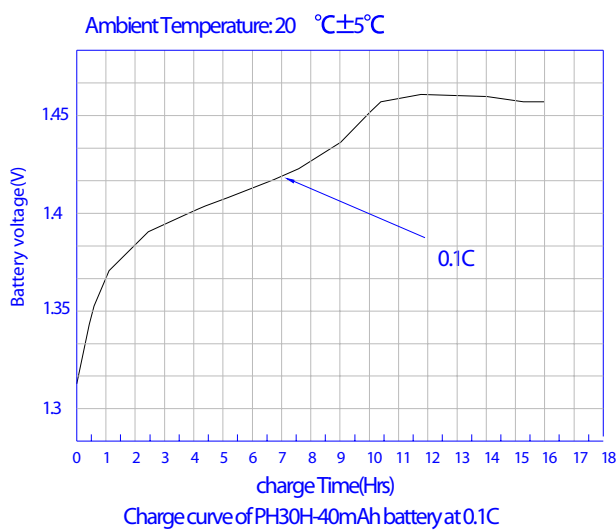

8. Caution

8.1 Please charge battery follow the instruction of item 5.1, charge current cannot be more than the limit of item 5.1. Overcharge with high current is harmful, it may cause battery deformation, leak or even explosion.

8.2 Do not discharge battery to the condition of lower voltage than 1.0V. Over discharge may decrease the cycle life and may cause battery deformation, leak or explosion.